

Español al Reverso



N-Dura



**Navis Global
World Headquarters**
113 Woodside Drive
Lexington, North Carolina 27292
PHONE 336-956-6444
TOLL FREE 866-882-3839
FAX 336-956-1795

www.navistubetex.com

A proud heritage. An innovative approach. A global network.

M&W began building stenters for the textile & plastic markets in 1920. When non-woven and technical webs entered the markets, M&W became the leader in servicing these applications requiring specialized stenters.

High Speed, High Pull, Robust Design, Energy Efficient, Easily Maintained, Long Life, Un-matched Customer Service are synonymous with the Marshall & Williams name.

Since its beginning, M&W is well known for building stenters that are both robust and durable under the most adverse conditions, while running the fastest speeds with minimal energy consumption.

In 2000, M&W was acquired by Navis TubeTex. Navis TubeTex has continued an extensive and vigorous development of the M&W technology and brand.



Stenter Applications

Technical Textiles



Woven Finishing



Nonwoven



Open Width Knit

Stenter Applications

Technical Textile/ Nonwoven

- High Speed & High Pull Capabilities
- Optimal Drying & Heating Rates
- Lowest Energy consumption for kg Processed
- Heat Recovery Systems Available
- Multiple Inlet / Outlet Configurations to match process
- Wide Range of Chemical Application technologies (Coating, Saturation, Foam)
- Powerful / Precise yet Intuitive Controls Platform
- Remote Access / Control
- Standard Widths up to 3.8 m / Wider widths available
- Turnkey Solutions

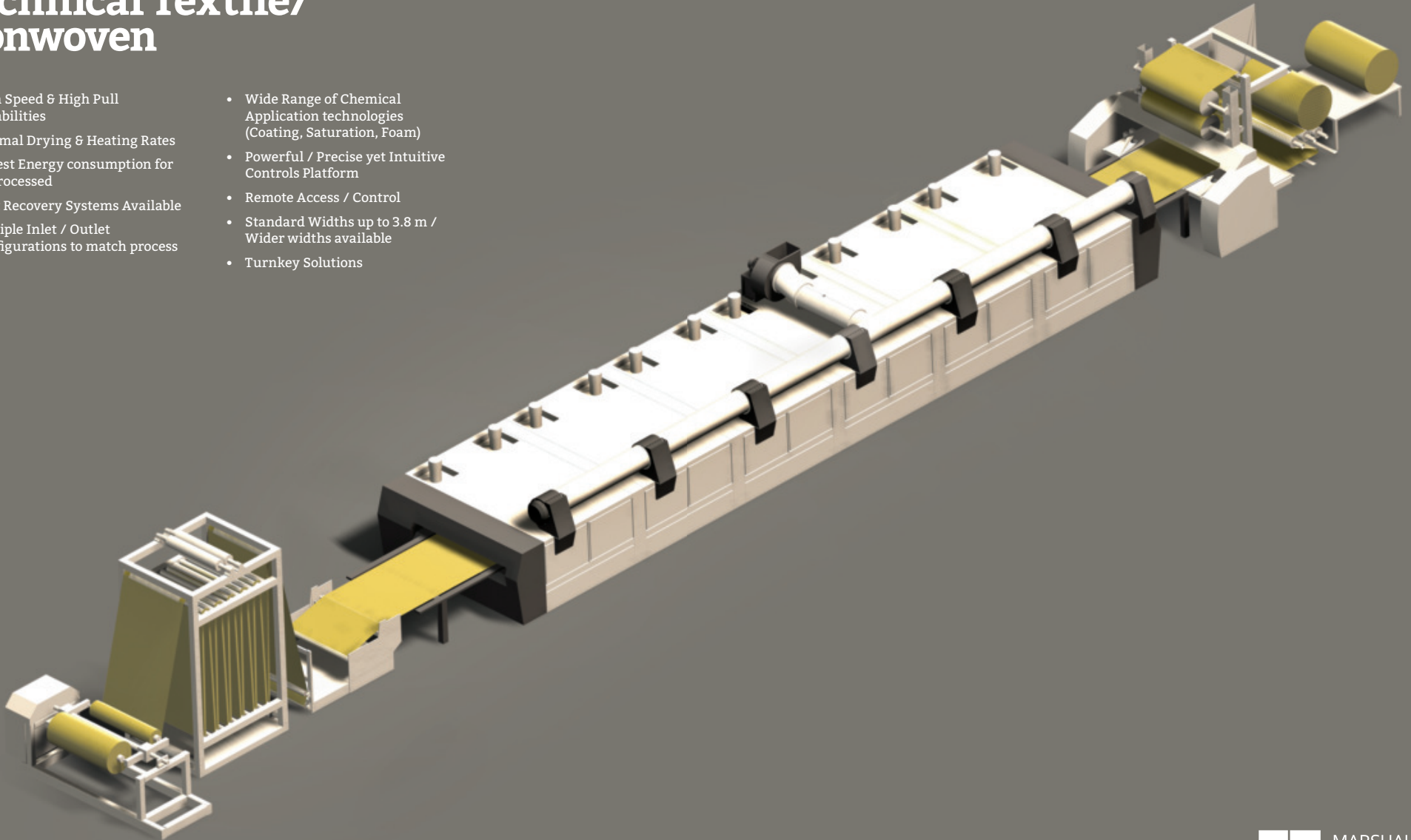

Stenter Applications

Open Width Knitted Fabrics

- Versatile for all knit fabrics fibers and constructions
- Overfeed rates to 60%
- Exceptionally Straight and Precise Pinning System
- Durable construction for many years of trouble free service
- Optimal Drying & Heating Rates
- Low Energy consumption per kg Processed
- Heat Recovery Systems Available
- Multiple Inlet / Outlet Configurations to match process
- Powerful / Precise yet Intuitive Control Platform
- Remote Access / Control
- Turnkey Solutions

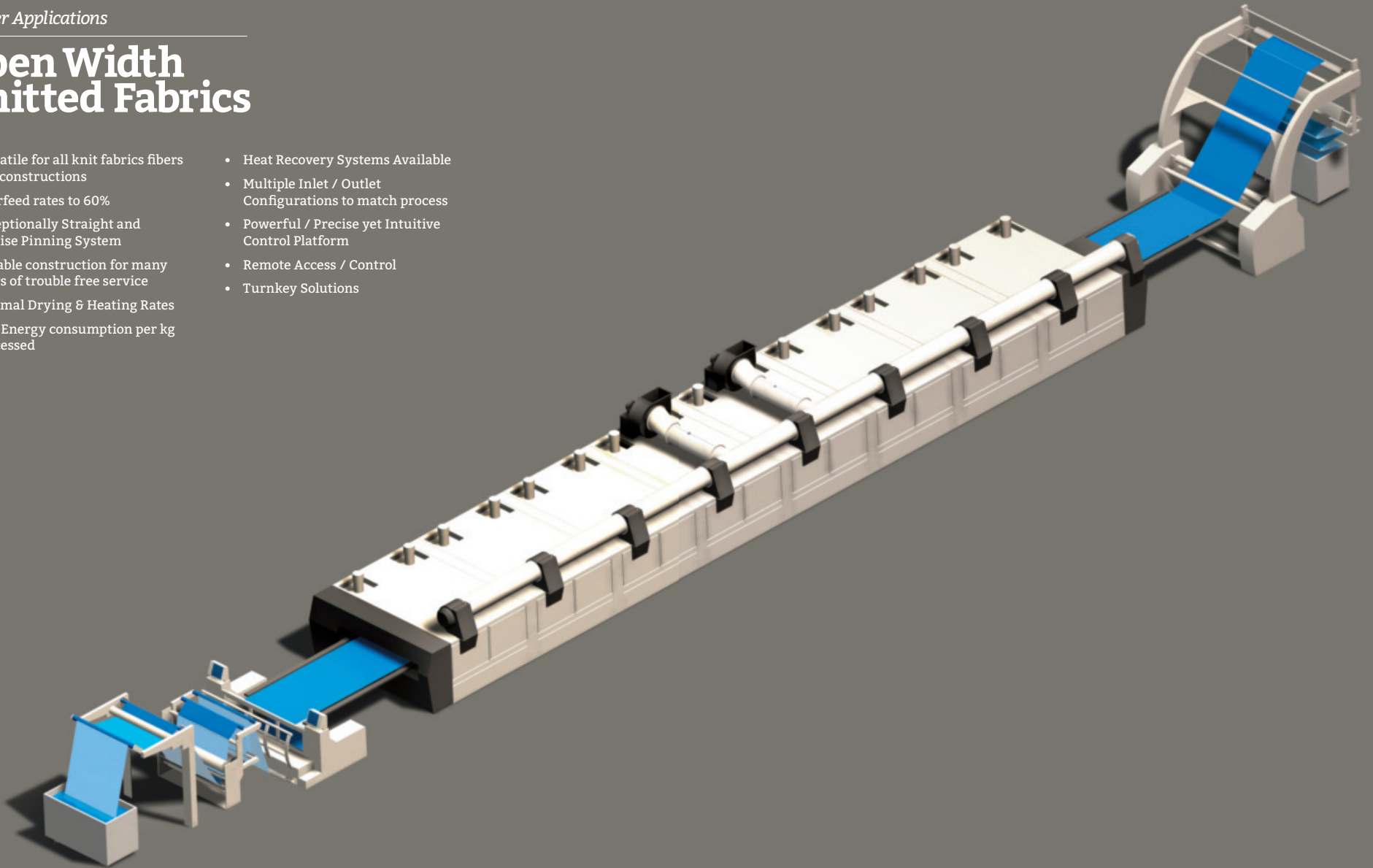

Stenter Applications

Woven Fabrics

- High Speed & High Pull Capabilities
- Versatile for many types of fabrics
- Clip, Pin or Combination Chain Styles Available
- Speeds to 200 m/m
- Optimal Drying & Heating Rates
- Low Energy consumption for kg Processed
- Heat Recovery Systems Available
- Multiple Inlet / Outlet Configurations to match process
- Wide Range of Chemical Application technologies (Coating, Saturation, Foam)
- Powerful / Precise yet Intuitive Control Platform
- Remote Access / Control
- Standard Widths up to 3.8 m
- Turnkey Solutions

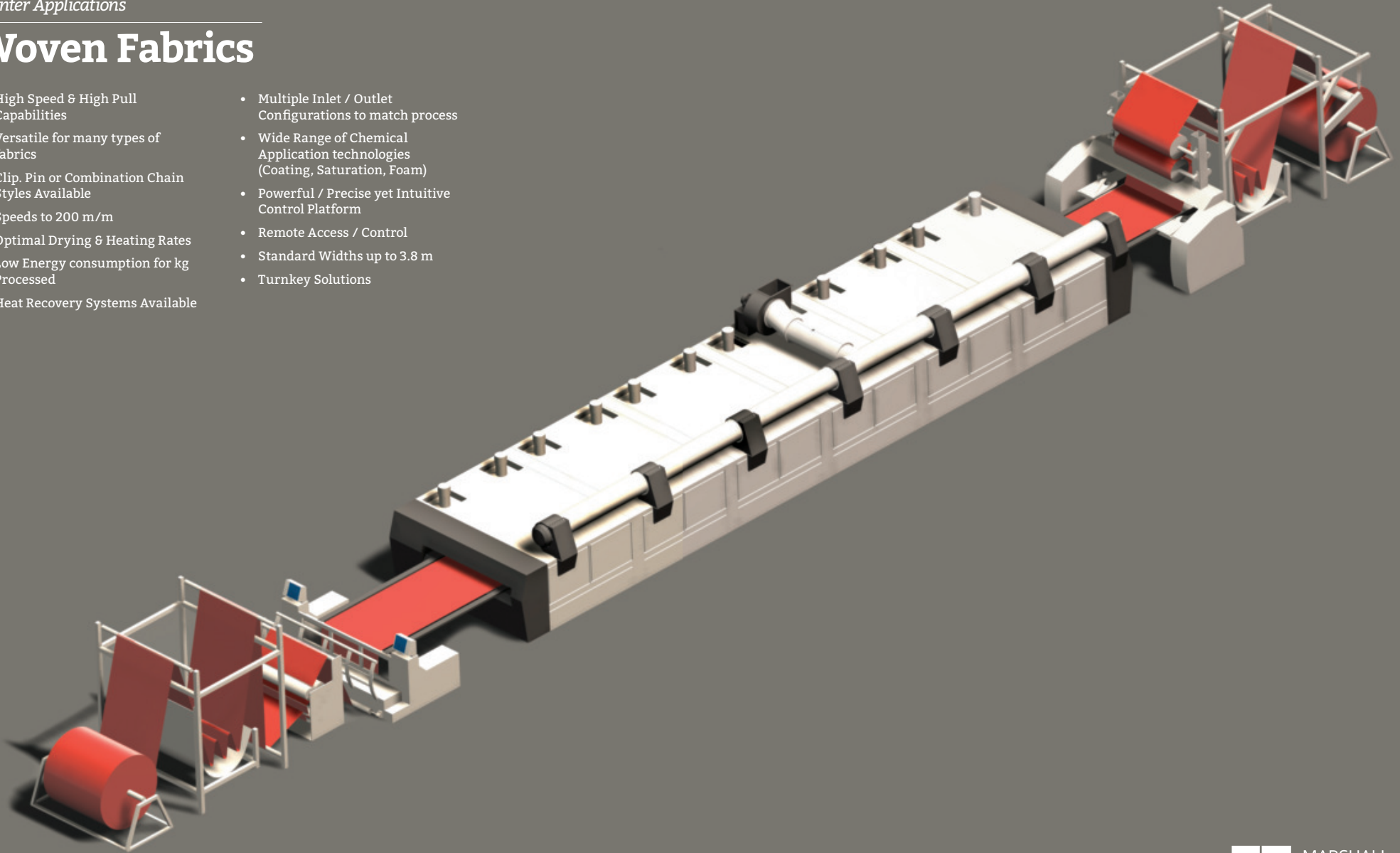

Series 2000 Chain

The Series 2000 is the leading M&W chain system. It incorporates over 90 years of tenter chain experience with the latest metal, plastic, manufacturing and lubrication technologies. Features of the design:

- Speeds up to 200 m/m; Loads 25N/mm+
- Only requires periodic Relubrication (~8000 hour intervals). Lubrication performed on machine (<8hrs).
- High temperature engineered plastic chain bushings for longer life than competitive designs.
- Available in Clip, Pin or Combination versions.
- Clip top knife & plate matched using a proprietary process.
- Operates with Low Maintenance Series 2000 Rails.

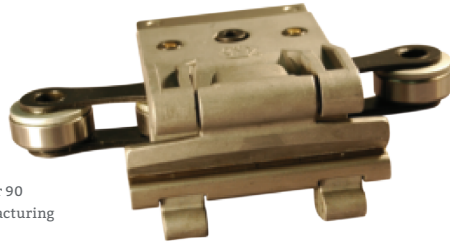

Series 2000 Rail Section

The 2000 rail system is the industry's most robust rail system. It is designed for millions of meters / years of trouble free / low maintenance operations. Details of the system:

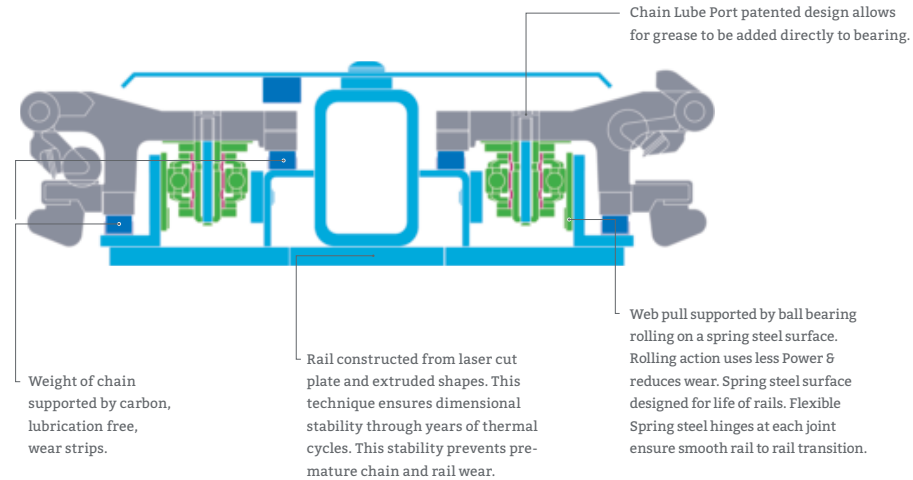

P5 Vertical Pin Chain & Rails

The P5 pin chain is the answer to applications requiring vertical pinning systems. Web control is maintained at even the highest overfeed rates because of the vertical design. The chain is manufactured using a unique power metal technology. Using powder metal gives an extremely straight pin line, precision lubrication passages and a high strength chain.

- Speeds up to 100 m/m
- Requires minimal lubrication.
- Low Profile design for minimum nozzle to fabric distance.
- No replaceable wear pads.
- Rail system protects chain and pins on the return path.
- Formed sheet steel rails prevent oil leakage to floor or surroundings.
- Hard Aluminum Bronze wear surfaces are designed for the life of the rails.

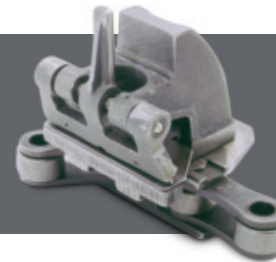
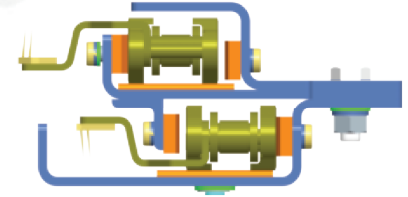

#48 Mercerizer

Designed for the heavy pulls associated with mercerizing, the #48 Clip Mercerizer horizontal, two-piece chain and rail assembly is designed for speeds up to 150 yds/min (137 m/min). The continuously self-lubricating chain bushing reduces maintenance and downtime.

Overfeed Pinning Systems

Proper pinning is the key to successful overfeed and yield control. **Available options:**

- Belt type or nip type pin-on system.
- Pneumatically actuated pinning roll for easy set-up.
- Driven and fixed style center cloth supports.
- Steaming systems.
- Adjustable tangency scroll rolls.
- Skew/Tilt roll.
- Individually adjustable draw rolls.
- Plate type or Finger type selvage uncurlers.

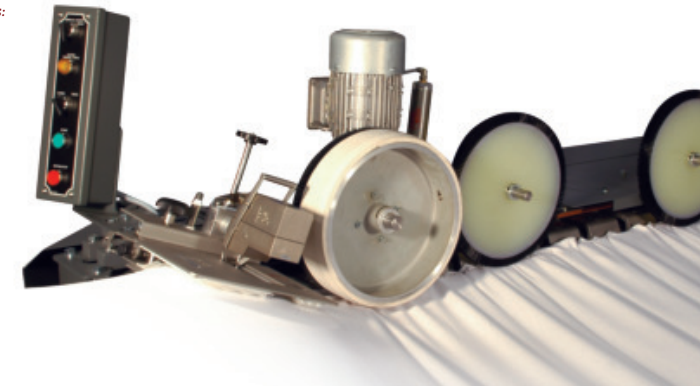

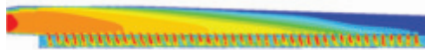
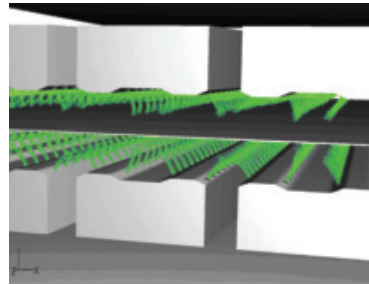
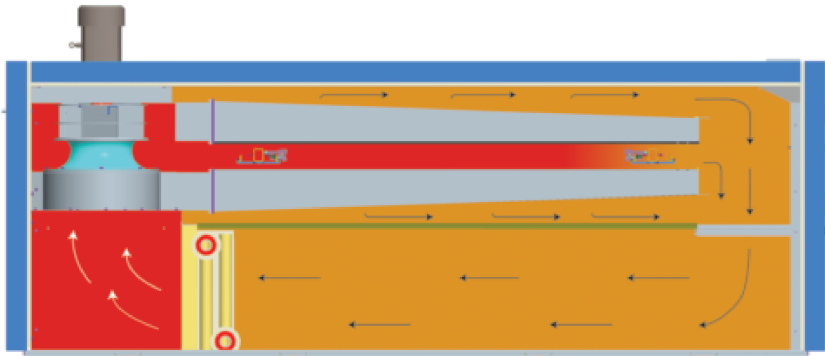

N-Dura Dryer

The N-Dura Dryer was developed by engineers using the latest thermal & aerodynamic modeling techniques to optimize air flow patterns and heat distribution; concurrently, industrial designers developed a structure that was easy to install, operate and maintain.

Performance Features

- Unique Nozzle design using CFD Analysis optimizes velocity and uniformity while minimizing power requirements.
- Heat Recovery (internal and stand alone) systems available. Savings are process dependent.
- Housing losses 43% less than conventional designs. Heat radiation to room is minimized.
- Heating Options: Steam, Thermal Oil, Gas Burners
- All wired & piped components (fans, burners, motors, coils) are located on same side of dryer minimizing floor space, providing easy access for cleaning, and facilitating easy installation and troubleshooting.

Filter Cleaning & Access



- 1 Individually removable nozzles with clean-out doors.
- 2 Large Return air filters cleaned while in operation. Frequency is process dependent.
- 3 Duplex filters ensure processed air is filtered during cleaning.

Width Adjustment System

- 1 Direct coupled gearmotors outside of dryer eliminate maintenance problems with chains and sprockets. Rails positioned to preset width (recipe or operator selectable).
- 2 Position Sensor displays rail location at each joint and eliminates damage caused by extreme rail angles.
- 3 Precision saddles support rails from tipping caused by pull forces and web close to nozzles for efficient heating and drying.
- 4 Width Adjustment screws below support beam prevent contamination of web.
- 5 Width adjustment mechanism easily accessed for maintenance.

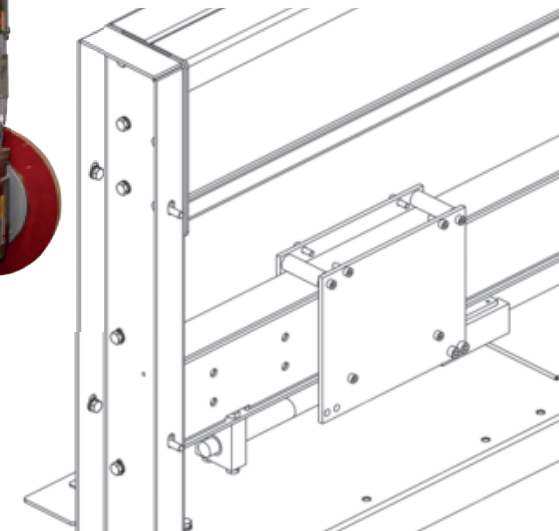
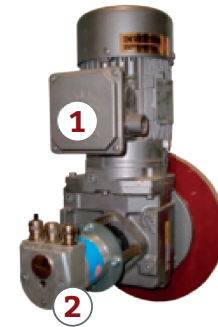

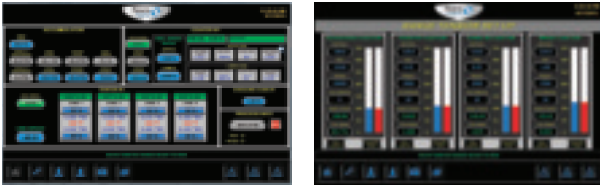

Range Controls

Compass is a complete control center for the entire range. Using the latest PLC's, digital drives, control software and color touch screens, the system is packed with range control features yet is easy to learn and intuitive to operate. The operator performs all range control functions by following icon based, multilingual dashboard style operator screens. The range can be completely controlled by the fully functional Compass terminals located at each end of the range.

Operator Controls

- Advanced Diagnostics accessible from dashboard or remote via modem (Standard Feature)
 - Error Codes
 - I/O conditions
 - Range parameters & Alarm History
 - Remote operation & trouble shooting
- Control Architecture Provides 3 password accessible levels of functionality. Each Mode is field customizable to accommodate facility operational procedures.
 - Operator Mode
 - Supervisor Mode
 - Maintenance Mode
- Heat Set Dwell Time Control
- Fabric Width Control
- Fabric Density / Stitch Controls
- Fabric Moisture Control
- Energy Saver Mode

Management Features

- Shift Manager - Run time efficiency. Logging of all stops and associated cause
- Maintenance Manager - with Life Tracker & Upcoming Maintenance events / Preventative Maintenance alerts
- SMS /Email alerts
- Data Collection Capabilities
- Range Utilities
- Tech Data (Schematics , PLC programs. Assembly drawings, Instruction Manuals)
- Reports in Portable Document Format

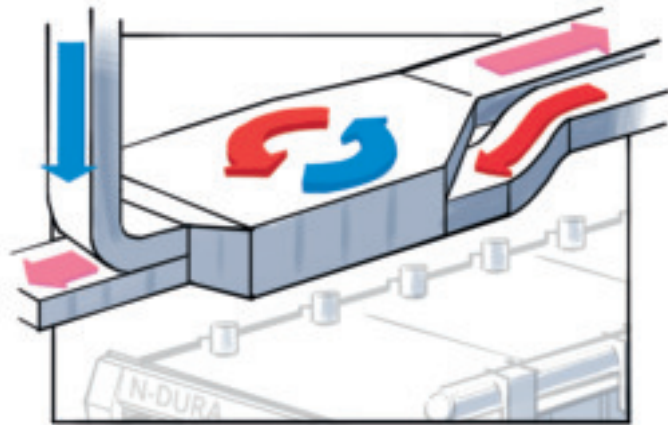

M&W Heat Recovery

M&W offers both integrated and stand-alone heat recovery systems for the N-Dura Stenter. Payback is often less than 1 year based on processing parameters and utility costs. Typical design returns heated make-up air to the dryer. External systems for heating water or air used elsewhere are available.

M&W Metal IR Gas pre-dryer

The M&W Metal IR Gas Pre-Dryer utilizes a high-efficiency radiant gas burner. Processors can specify the size and location of the pre-dryer based on individual Stenter range applications.

Advanced Burner Design

- Even heating and drying
- Optional burner width selection for energy savings
- Floor or overhead mounting options
- Large-diameter stainless steel idler rolls with optional water cooling
- Full-width access doors and individually removable burners for ease of maintenance

